

Installation, Operation, and Maintenance (IOM) Manual for Flanged Globe Valves

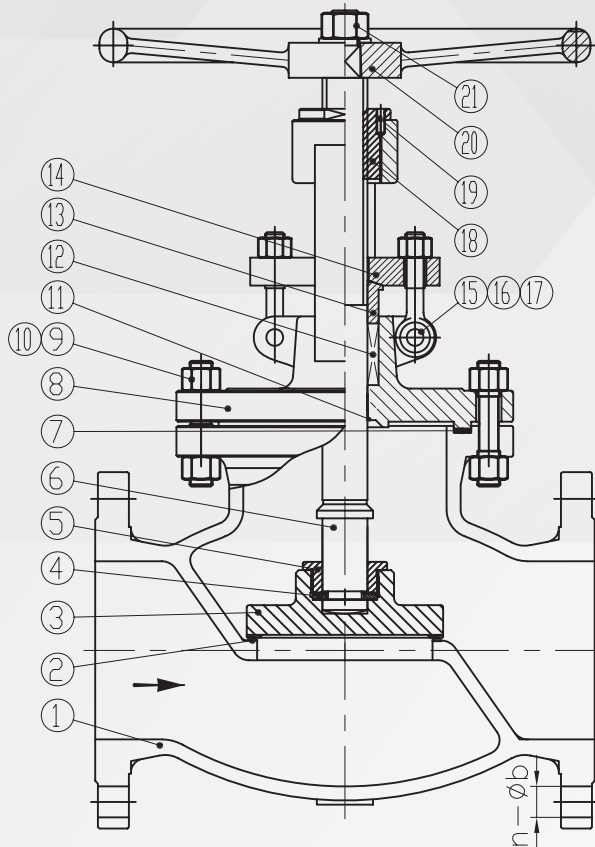

21	H. W. LOCK NUT
20	HANDWHEEL
19	SCREW
18	STEM NUT
17	GLAND NUT
16	GLAND BOLT
15	PIN
14	GLAND
13	BUSHING
12	PACKING
11	BACKSEAT
10	NUT
9	STUD
8	BONNET
7	GASKET
6	STEM
5	DISC COVER
4	SPLIT RING
3	DISC
2	SEAT RING
1	BODY

Refer to the diagram and parts list above for a detailed view of each component, assisting with installation, operation, and maintenance for optimal valve performance.



ANIX VALVE CO.LTD, Certified ISO 9001.

www.anixusa.com

Note: This manual provides guidance for the proper installation, operation, and maintenance of flanged globe valves to ensure efficient performance and long-lasting service. It includes general practices for safe usage, regular inspection, and potential troubleshooting. We are not liable for damages arising from its use. Consult a professional if you have specific concerns related to your application or environment. For additional assistance, contact your supplier or representative.

GENERAL INFORMATION

- A globe valve is a type of linear-motion valve designed for controlling or throttling flow. It achieves shutoff by adjusting the disc against the flow stream. Unlike gate valves, globe valves redirect the flow path, which can result in a higher pressure drop. This valve is suited for applications where precise flow control is required.

HANDLING AND TRANSPORTATION

- **To avoid damage, handle all valves carefully during unloading and transport:**
 - Avoid damaging or scratching the protective coating.
 - Do not drop the valve; instead, carefully lower it from the transport vehicle.
 - For larger valves, use suitable equipment like forklifts or slings placed around the valve body or skids, ensuring they are secured with devices rated for the weight of the valve.
 - Avoid hooking onto or wrapping chains around vulnerable parts like the stem, handwheel, or yoke to prevent damage.





ANIX VALVE CO.LTD, Certified ISO 9001.
www.anixusa.com

STORAGE GUIDELINES

- **Proper storage can prolong valve life and performance:**
 - Store valves in the closed position to prevent contamination on seating surfaces.
 - Keep protective caps in place until installation.
 - If stored indoors, maintain dry, cool conditions out of direct sunlight and away from corrosive substances.
 - For outdoor storage, cover valves to protect them from weather, UV exposure, and debris.
 - In cold climates, ensure valves are dry before storage to prevent freeze damage.

PRE-INSTALLATION INSPECTION

- **Upon receiving the valve, inspect it thoroughly:**
 - Verify the type, size, pressure and temperature rating, and end connections meet requirements.
 - Check for any shipping damage, such as bent stems, broken parts, or missing components.
 - Ensure the valve can open and close fully before installation. If there are any issues, contact your supplier immediately.





ANIX VALVE CO.LTD, Certified ISO 9001.
www.anixusa.com

INSTALLATION INSTRUCTIONS

- **Before installation, ensure the valve and surrounding area meet these guidelines:**
 - Remove any debris inside the valve.
 - Install valves in a horizontal or vertical pipeline according to application needs, with the stem in an upright position.
 - Confirm the direction of the medium matches the flow direction indicated on the valve.
 - Center the valve flanges accurately and align them to avoid stress on the valve body.
 - Use appropriate gaskets and ensure all flanges are cooled to ambient temperature if welded nearby.
 - Tighten bolts in a crosswise pattern to ensure even pressure distribution across the gasket surface.

OPERATION

- **Globe valves are generally used to regulate flow. Operate them by hand:**
 - Open and close the valve by rotating the handwheel in the designated direction. Avoid using tools, which could damage the valve.
 - When the valve reaches the fully open position, turn it slightly towards the closed position to relieve stress on the stem.
 - Operate within the specified torque limits to avoid damaging the valve components.





ANIX VALVE CO.LTD, Certified ISO 9001.

www.anixusa.com

MAINTENANCE

- While globe valves are designed for long-term use with minimal maintenance, periodic inspections are recommended:
 - Every 4–5 years, inspect the valve for any signs of leaks or wear on flange gaskets and stem seals.
 - Tighten flange bolts as needed to account for gasket compression.
 - If any leakage is detected around the packing area due to stem movement, tighten the packing gland.

Safety Note: Ensure the valve is isolated and depressurized before performing any maintenance or repairs to prevent injury or equipment damage.

SAFETY WARNINGS

- Following these guidelines will help ensure safe valve operation:
 - Always match the valve's working pressure and temperature ratings with the system requirements.
 - Prior to maintenance or disassembly, make sure the valve is isolated from system pressure.
 - If the operating temperature exceeds the valve's rating, material degradation may occur, potentially leading to leaks or breakage.

Caution: For hazardous or pressurized media, ensure that personnel wear appropriate protective equipment during any valve servicing.

